



#### Principal characteristics

- The side connection creates a through-rod structure with double rod support, guaranteeing greater overall strength of the transducer.
- The return spring automatically returns the rod to zero position, making the transducer suitable for comparator applications.
- The tip with roller bearing is suitable for applications where the object to be measured may be subject to shifts transverse to the transducer axle (shaft is prevented from rotating).
- Ideal for checking the flatness or thickness of panels of various materials. Can also be used for valves or mechanical parts when the rod cannot be attached to the moving object.

#### TECHNICAL DATA

Useful electrical stroke (C.E.U.)	10/25/50
Resolution	Infinite
Independent linearity (within C.E.U.)	see table
Displacement speed	≤ 10 m/s
Displacement force	≤ 4 N
Life	>25x10 <sup>6</sup> m strokes, or 100x10 <sup>6</sup> operations, whichever is less (within C.E.U.)
Vibrations	5...2000Hz, Amax =0,75 mm amax. = 20 g
Shock	50 g, 11ms.
Tolerance on resistance	± 20%
Recommended cursor current	< 0,1 μA
Maximum cursor current	10mA
Maximum applicable voltage	see table
Electrical isolation	>100MΩ a 500V~, 1bar, 2s
Dielectric strength	< 100 μA a 500V~, 50Hz, 2s, 1bar
Dissipation at 40°C (0W at 120°C)	see table
Actual Temperature Coefficient of the output voltage	< 1,5ppm/°C
Working temperature	-30...+100°C
Storage temperature	-50...+120°C
Case material	Anodised aluminium Nylon 66 G 25
Control rod material	Stainless steel AISI 303
Fixing	Brackets with variable longitudinal axis

#### MECHANICAL DIMENSIONS

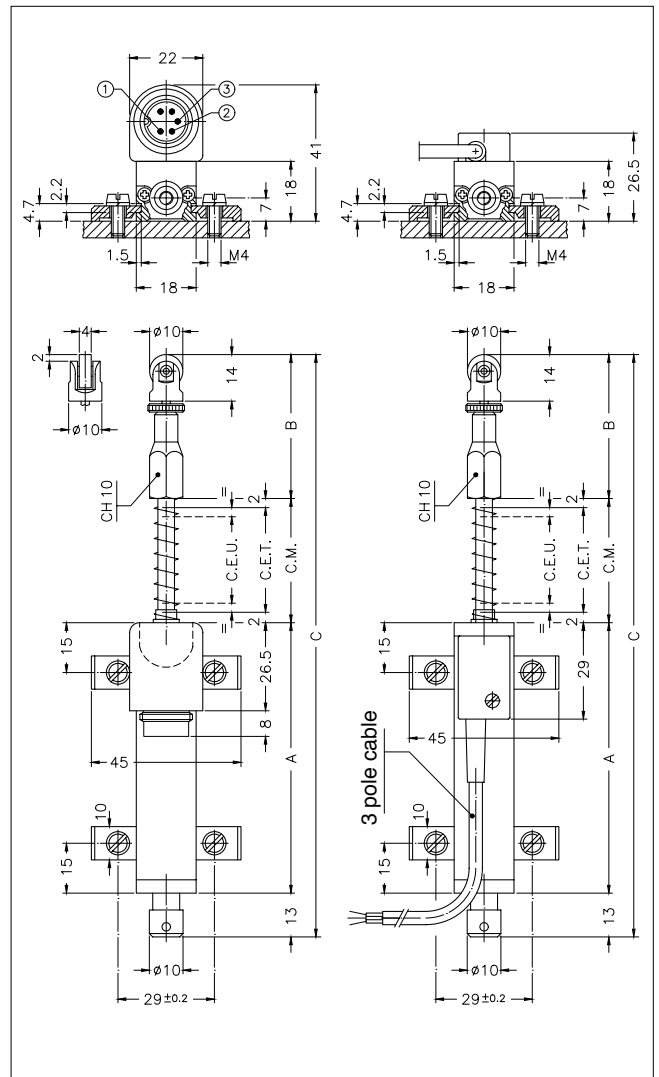

**Important:** all the data reported in the catalogue linearity, lifetime, temperature coefficient are valid for a sensor utilization as a ratiometric device with a max current across the cursor  $I_c \leq 0.1 \mu A$ .

## MECHANICAL / ELECTRICAL DATA

Model		10	25	50
Useful electrical stroke (C.E.U.) +1/-0	mm	10	25	50
Theoretical electrical stroke (C.E.T.) ±1	mm	C.E.U. +1		
Resistance (C.E.T.)	kΩ	1	1	5
Independent linearity (within C.E.U.)	± %	0.3	0.2	0.1
Dissipation at 40° (0W at 120°C)	W	0.2	0.6	1.2
Maximum applicable voltage	V	14	25	60
Mechanical stroke (C.M.)	mm	C.E.U. + 5		
Case length (A)	mm	C.E.U. + 38		
Tip length (B)	mm	43	43	51
Total length (C)	mm	119	149	207

## ELECTRICAL CONNECTIONS

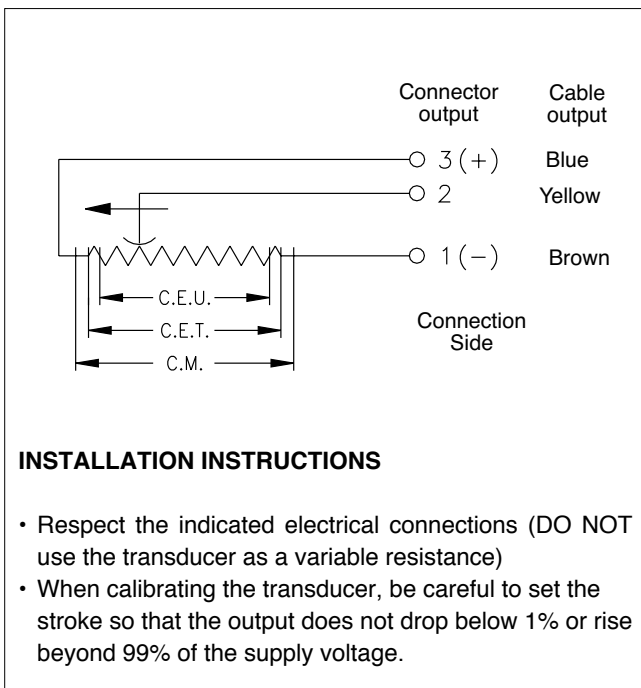

## OPTIONAL FIXING KIT PKIT006

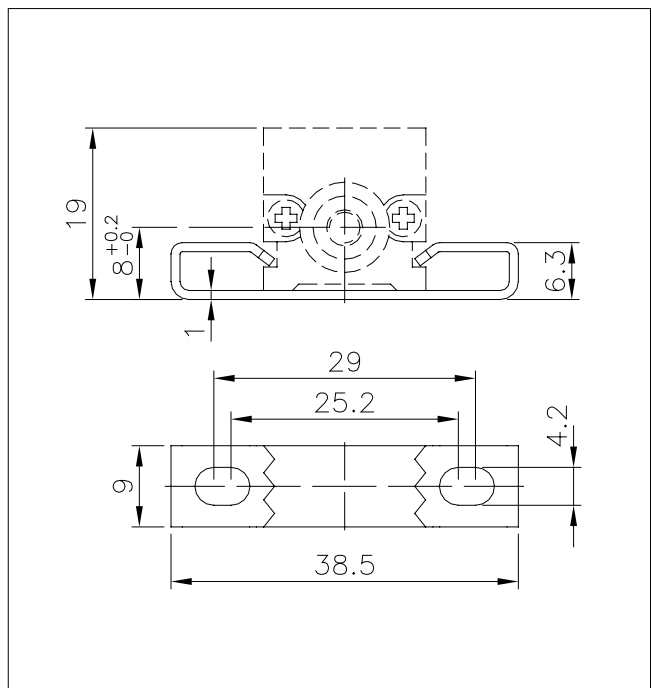

## ORDER CODE

**Displacement transducer PY3**

3 pole PVC cable output 3x0.25 1m	F
5 pole connector output DIN 43322	C

**Model**

<b>S</b> <input type="checkbox"/> <b>M</b> <input type="checkbox"/>	<b>Cable length (in metres)</b>
<input type="text"/>	

This part of the code only applies to the model with cable output

No certificate attached	0
Linearity curve to be attached	L
Standard mounting brackets (PKIT005)	X
Optional mounting brackets (PKIT006)	S
Color of plastic heads (green)	0
Color of plastic heads (black)	N

**Order Code Example:** 0000X00000

**Ex.: PY3 - C - 50**  
Displacement transducer model PY3, 5-pole connector output, useful electrical stroke (C.E.U.) 50mm.

## ACCESSORIES

### STANDARD ACCESSORIES

Fixing kit: 4 brackets, M4x10 screws, washer	<b>PKIT005</b>
Fixing kit: 2 "wraparound" brackets (0000X000S00 configurator option)	<b>PKIT006</b>
Bearing tip	<b>PTAS001</b>

### OPTIONAL ACCESSORIES

5-pin axial female PCB connector DIN43322 IP40 clamp for wire $\varnothing 4 - \varnothing 6$ mm	<b>CON011</b>
5-pin axial female PCB connector DIN43322 IP65 clamp PG7 for wire $\varnothing 4 - \varnothing 6$ mm	<b>CON012</b>
5-pin 90° radial female PCB connector DIN43322 IP40 clamp for wire $\varnothing 4 - \varnothing 6$ mm	<b>CON013</b>

**GEFRAN spa** reserves the right to make any kind of design or functional modification at any moment without prior notice